



American Earth Anchors

The best screw you will have in the dirt™

PE9 | Specifications

9" Penetrator™

- Aircraft-quality cast aluminum 356 alloy
- Heat-treated to T6 specification
- Install with 3/4" or 19 mm socket
- Removable

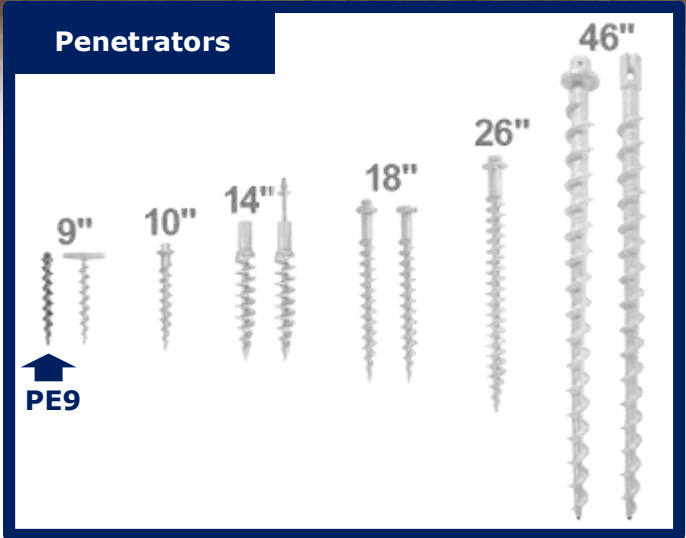

9"
(23 cm)

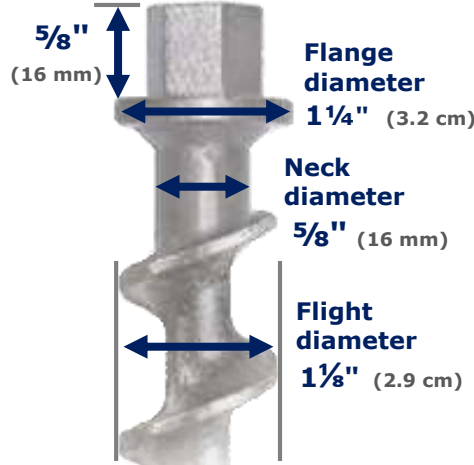

Flange diameter
1 1/4" (3.2 cm)

Neck diameter
5/8" (16 mm)

Flight diameter
1 1/8" (2.9 cm)

Socket size
3/4" (19 mm)



LOAD CAPACITY

Pullout strength with flight fully embedded

Hardpan or asphalt	Soil Class 1 Dense sand or gravel	Soil Class 2 Medium sandy gravel	Soil Class 3 Loose medium-to-fine sand	Soil Class 4 Loose fine uncompacted sand
400 lb 1.78 kN	200 lb 0.89 kN	100 lb 0.44 kN	Less than 100 lb 0.44 kN	Less than 100 lb 0.44 kN

©2014 American Earth Anchors
SS-PE9 Nov 2014



American Earth Anchors
info@americanea.com
americanea.com

Contact us for CUSTOM WORK
Size, length, shape, material,
prototypes, cable assemblies



866-520-8511
+1 508-520-8511

PE9 | Installation

Installation method



Impact wrench

 **Attachment accessory**

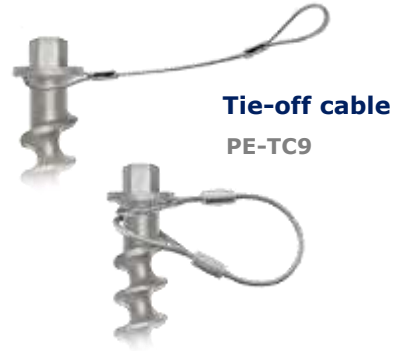

Tie-off cable
PE-TC9

